

112ET000 SC

Reference	Item number	Qty	Description
1	1112 020 2100	1	Crankcase □ 2 - 5
2	9371 470 3120	2	Cylindrical pin 6x20
3	9048 216 1010	6	Pan head screw M5x18
4	1112 122 3900	1	Elbow connector
5	1110 122 3900	3	Elbow connector
6	1108 647 9401	1	Hose
7	1106 640 3801	1	Pickup body
8	9503 003 0340	1	Grooved ball bearing 6202
9	9456 621 3860	1	Circlip 35x1.5
10	9629 003 2860	1	Oil seal 25x37x7
11	9503 003 0310	1	Grooved ball bearing 6002
12	9640 003 1570	1	Oil seal 15x24x7
13	1110 029 0500	1	Gasket
14	1110 030 0400	1	Crankshaft
15	9048 319 0980	2	Pan head screw M5x16
16	1110 029 2300	1	Cylinder gasket
17	1110 020 1210	1	Cylinder with piston Ø 44 mm □ 18 - 21
18	1110 030 2000	1	Piston Ø 44 mm □ 19 - 21
18	1110 030 2005	1	Piston Ø 44 mm □ 19 - 21
19	1110 034 1500	1	Piston pin 10x6x32
20	9462 650 1000	2	Snap ring 10
21	1110 034 3000	2	Piston ring Ø 44x1.5 mm
22	9512 003 2340	1	Needle cage 10x14x13
23	9036 341 0980	4	Socket head screw M5x16

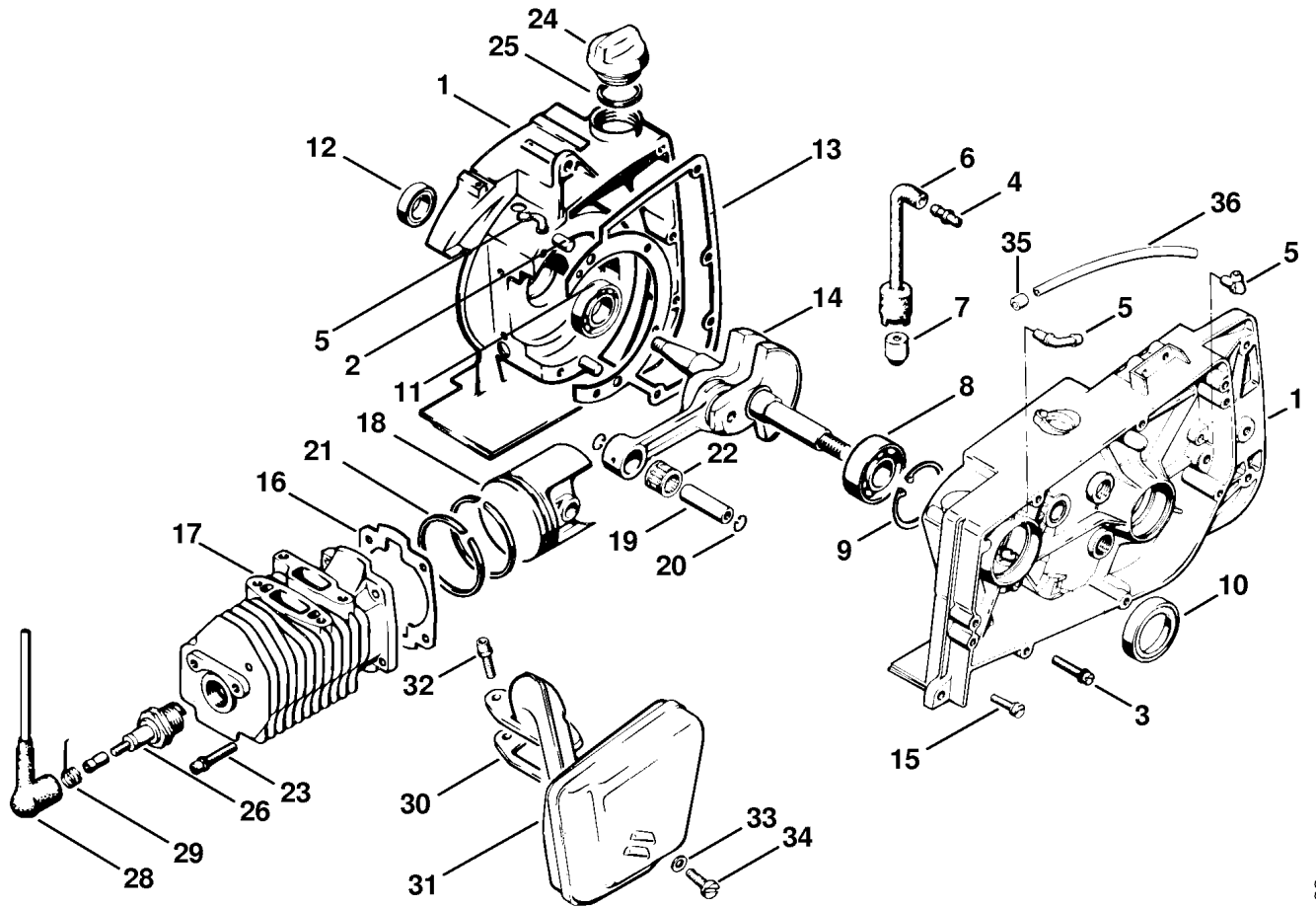

112ET000 SC

Reference	Item number	Qty	Description
24	1114 640 3600	1	Oil filler cap □ 25
25	0000 992 6305	1	Sealing ring
26	1110 400 7005	1	Spark plug Bosch WSR 6 F
28	1106 405 1000	1	Spark plug boot
29	0000 998 0603	1	Torsion spring
30	1110 149 0600	1	Muffler gasket
31	1110 140 0601	1	Muffler
32	9036 341 0980	2	Socket head screw M5x16
33	9291 021 0120	1	Washer 5.3
34	9048 216 1010	1	Pan head screw M5x18
35	0000 961 0501	2	Ring
36		1	Hose 3.1x5.7x135 mm (D)
	0000 930 2803	1	Hose 3.1x5.7 mm x 1 m (A,B)

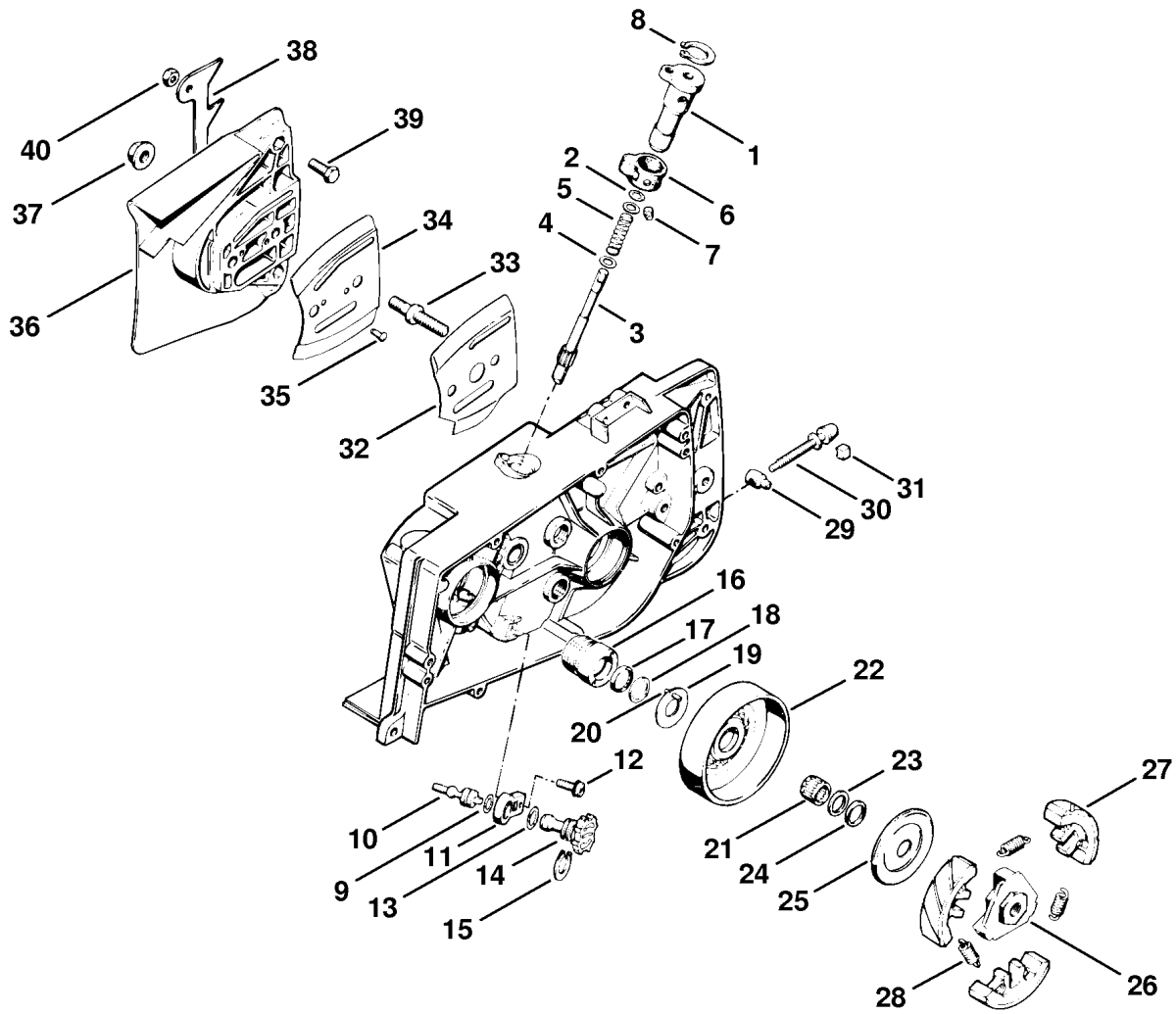

112ET002.LA

Reference	Item number	Qty	Description
	1110 640 3200	1	Oil pump □ 1 - 7
1	1110 640 3000	1	Pump housing
2	9646 945 0340	1	O-ring 6x1.5
3	1110 647 0601	1	Pump piston
4	0000 958 0602	2	Washer
5	0000 997 0805	1	Compression spring
6	1110 647 9000	1	Rubber ring
7	0000 963 0501	2	Bushing
8	9456 621 2140	1	Circlip 20x1
9	9646 945 0490	1	O-ring 7x1.5
10	1110 647 4800	1	Control bolt
11	1112 647 5000	1	Support
12	9048 216 1010	1	Pan head screw M5x18
13	9646 945 0590	1	O-ring 8x2
14	1110 647 4900	1	Control knob
15	9460 624 0800	1	E-clip 8
16	1110 640 7100	1	Worm □ 17, 18
17	9643 003 1160	1	Sealing ring 12x16x3
18	1110 647 9705	1	Ring
19	1112 640 8600	1	Washer □ 20
20	9371 651 1360	1	Cylindrical pin 2.5x11
21	9512 003 2400	1	Needle cage 12x15x10
22	1112 640 2500	1	Drive pinion
23	0000 958 1211	1	Washer
24	9643 003 1160	1	Sealing ring 12x16x3
25	1110 162 8900	1	Washer

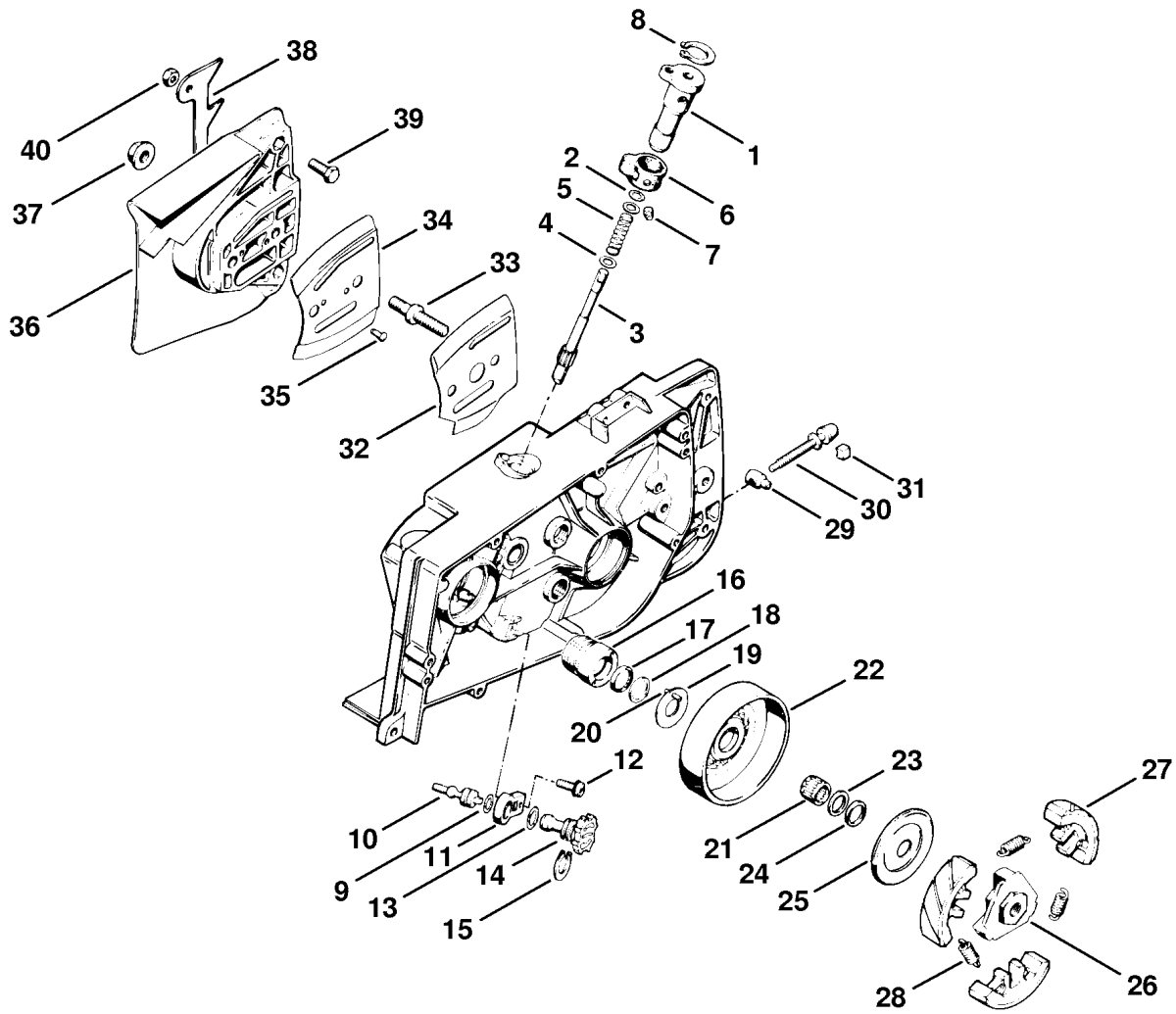

112ET002.LA

Reference	Item number	Qty	Description
	1112 160 2000	1	Clutch □ 26 - 28
26	1113 162 3205	1	Carrier
27	1112 160 1500	3	Clutch shoe
28	0000 997 5728	3	Tension spring
29	1110 664 1500	1	Tensioning nut
30	1110 664 1600	1	Adjusting screw
31	1110 021 9000	1	Clamp
32	1113 664 1100	1	Outer side plate
33	1110 664 2400	2	Collar screw
34	1112 664 1000	1	Inner side plate
35	9441 065 1910	2	Round head rivet 3x8
36	1112 648 0400	1	Chain sprocket cover
37	9220 260 1100	2	Hexagon nut M8
38	1110 664 0501	2	Bumper spike
39	9008 319 0960	4	Hexagon head screw M5x12
40	9214 320 0700	4	Lock nut M5

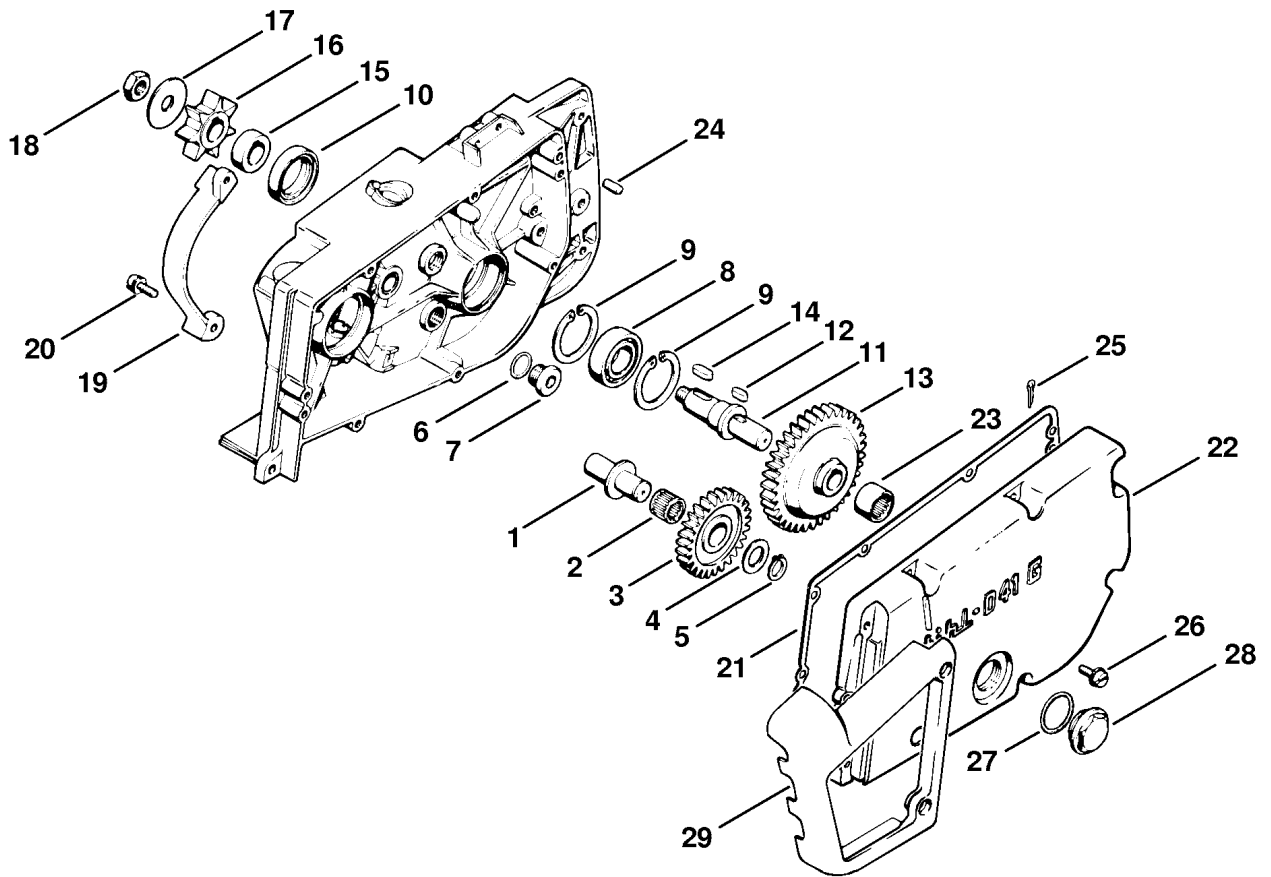

112ET003.LA

Reference	Item number	Qty	Description
1	1112 642 2300	1	Axle
2	9512 003 3000	1	Needle cage 12x15x13
3	1112 642 1500	1	Spur gear
4	0000 958 1208	1	Washer
5	9455 621 1130	1	Circlip 12x1
6	9636 965 1160	2	Sealing ring 12x16
7	0000 951 7103	2	Screw plug M11
8	9503 003 0410	1	Grooved ball bearing 6003
9	9456 621 3860	2	Circlip 35x1.5
10	9640 003 2570	1	Oil seal 22x35x7
11	1112 642 0600	1	Drive shaft
12	9470 435 0510	1	Key 4x4x10
13	1112 642 1510	1	Spur gear
14	9470 435 0900	1	Key 5x3x14
15	1112 642 8200	1	Ring
16	1112 642 1300	1	Rim sprocket kit 0.404" 7T
17	0000 958 1012	1	Washer
18	9211 260 1340	1	Hexagon nut M10x1
19	1112 656 1500	1	Guard plate
20	9048 216 1010	2	Pan head screw M5x18
21	1112 649 0500	1	Gasket
22	1112 641 0400	1	Gearbox cover
23	9513 003 2760	1	Needle cage 12x18x12
24	9371 470 2610	2	Cylindrical pin 5x18
25	9395 021 0790	1	Split pin 1.6x12
26	9048 216 1010	9	Pan head screw M5x18
27	9636 965 2500	1	Sealing ring 22x27
28	0000 951 7204	1	Screw plug M22x1.5
29	1112 146 6000	1	Guard

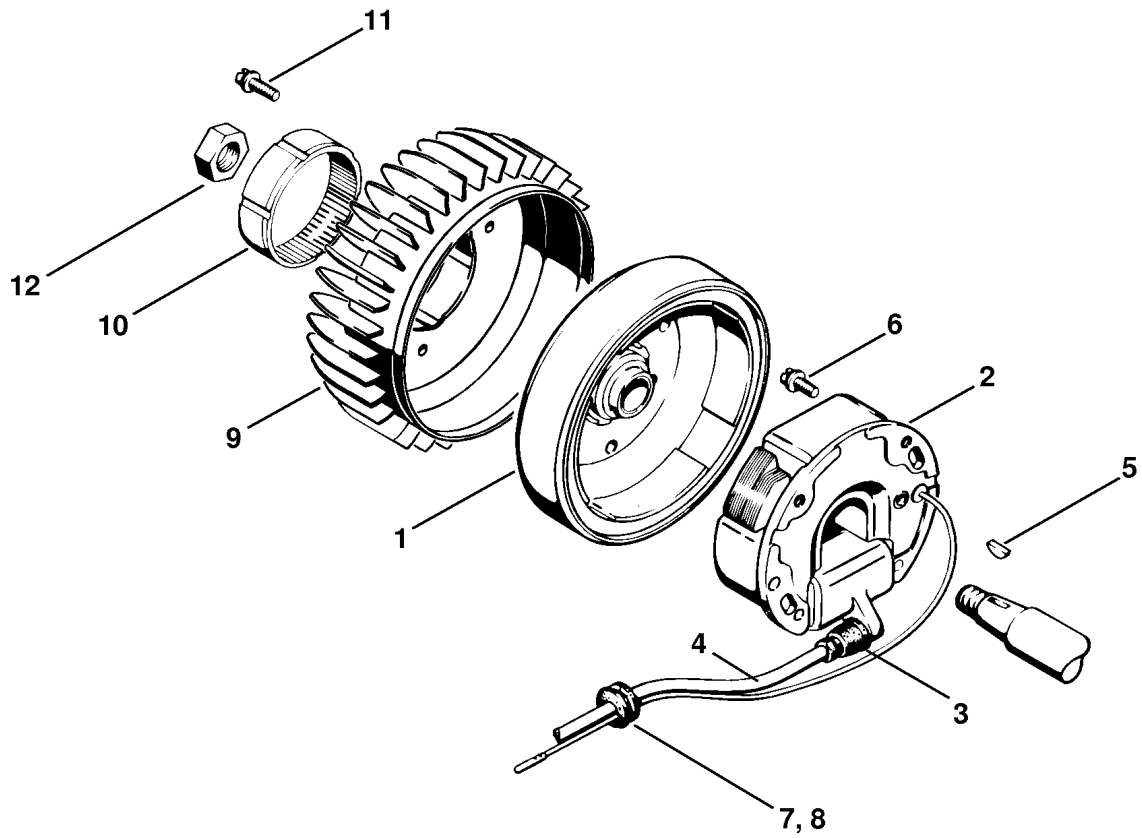

112ET004.LA

Reference	Item number	Qty	Description
	1110 400 0506	1	Magneto □ 1 - 4
1	1110 400 1206	1	Flywheel
2	1110 400 0807	1	Stator plate
3	0000 989 1010	1	Grommet
4	1110 405 0600	1	Ignition lead 290 mm
5	9482 435 0030	1	Woodruff key 2x3.7
6	9021 319 0670	2	Pan head screw M4x14
7	0000 989 0804	1	Grommet
8	0000 989 0801	1	Grommet
9	1110 080 0500	1	Fanwheel □ 10
10	0000 961 5116	1	Ring
11	9048 319 0700	3	Pan head screw M4x18
12	9210 261 1140	1	Hexagon nut M8x1

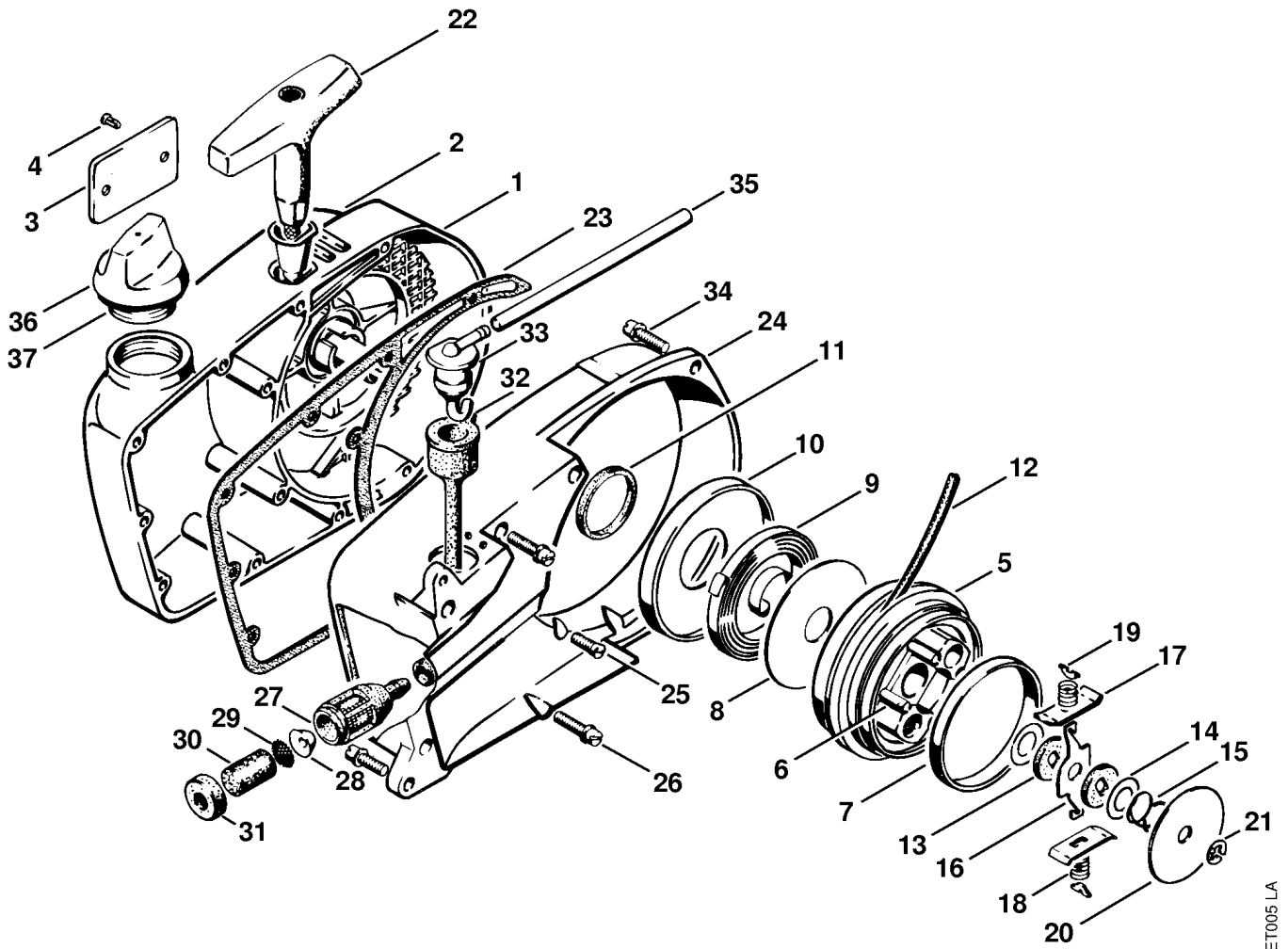

112ET005 LA

Reference	Item number	Qty	Description
	1110 080 2810	1	Fan cover with rewind starter □ 1 - 22
1	1110 080 2800	1	Fan cover □ 2 - 4
2	1110 084 9102	1	Bushing
3	0000 967 2020	1	Nameplate STIHL
4	9441 065 1270	2	Round head rivet 2.6x6
5	1110 190 1001	1	Rope rotor □ 6, 7
6	1106 195 9800	4	Notched pin
7	1110 195 9301	1	Ring
8	1111 195 9005	1	Washer
9	1111 195 1600	1	Rewind spring
10	1111 195 1300	1	Cover
11	0000 988 2405	1	Felt ring
12	1107 195 8200	1	Starter rope Ø 4.5x1000 mm
	0000 930 2200	1	Starter rope Ø 4.5 mm x 30.5 m (A,B)
13	1106 195 9001	2	Washer
14	0000 958 1010	2	Washer
	1106 190 4600	1	Friction shoe □ 15 - 19
15	1106 195 2900	1	Brake spring
16	1106 195 3000	1	Brake lever
17	1106 195 5000	2	Friction shoe plate
18	1106 195 5100	2	Friction shoe spring
19	1106 195 1700	2	Spring retainer plate
20	1106 195 3200	1	Thrust washer
21	9460 624 0500	1	E-clip 5
22	1110 195 3400	1	Starter grip

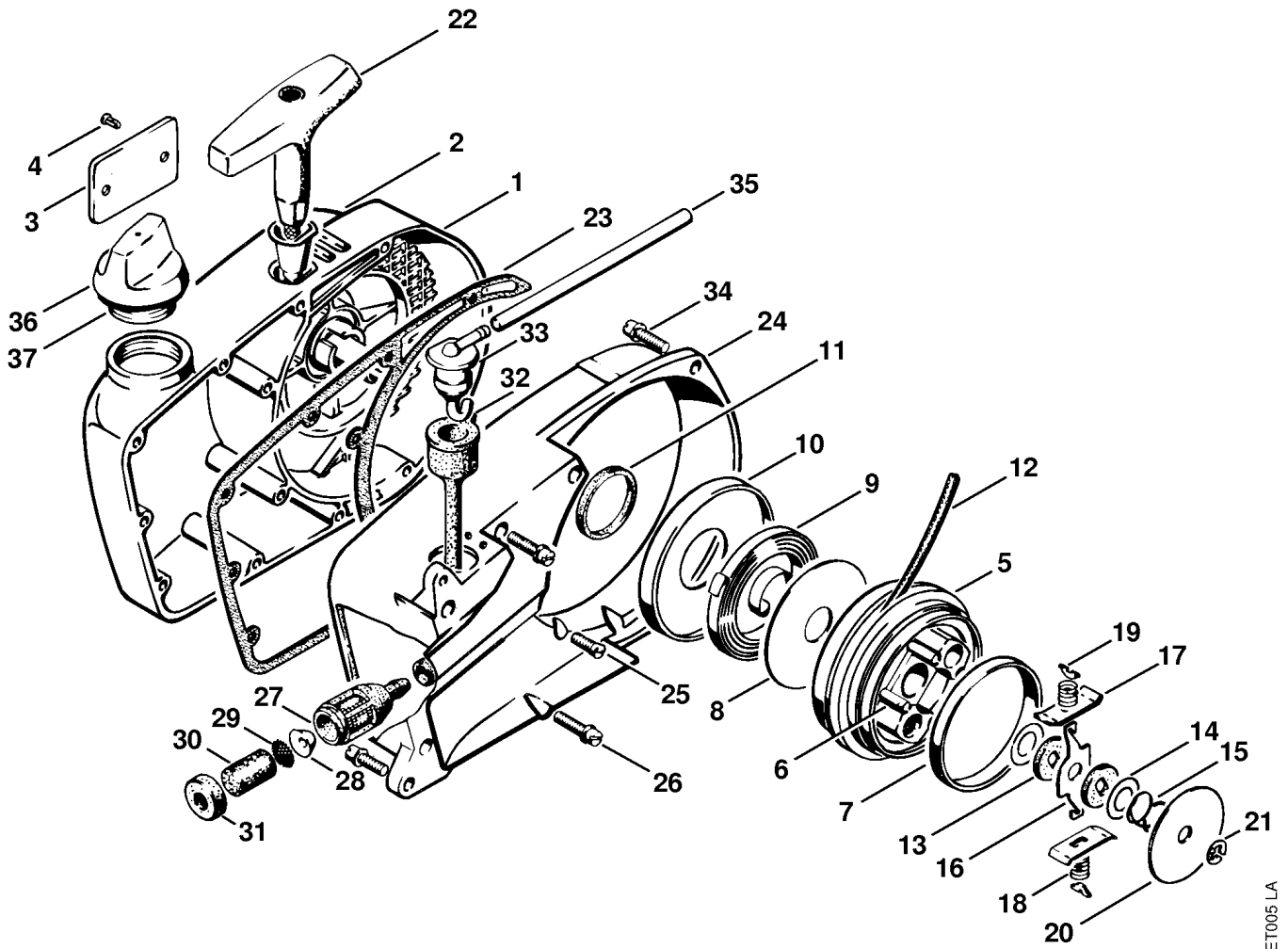

112ET005 LA

Reference	Item number	Qty	Description
23	1110 359 0701	1	Gasket
24	1110 084 1000	1	Fan housing
25	9062 319 0660	2	Countersunk screw M4x12
26	9048 319 0660	9	Pan head screw M4x12
	1115 350 3501	1	Pickup body □ 27 - 31
27	1111 350 3500	1	Pickup body
28	1111 358 9100	1	Insert
29	1111 358 9300	1	Strainer
30	1110 358 1800	1	Filter
31	1111 358 2500	1	Cap
32	1113 358 7700	1	Hose
33	1110 350 1200	1	Elbow connector
34	9048 216 1010	4	Pan head screw M5x18
35		1	Hose 3.1x5.7x135 mm (D)
	0000 930 2803	1	Hose 3.1x5.7 mm x 1 m (A,B)
36	1110 350 0500	1	Filler cap □ 37
37	9645 945 2820	1	O-ring 25x2.5

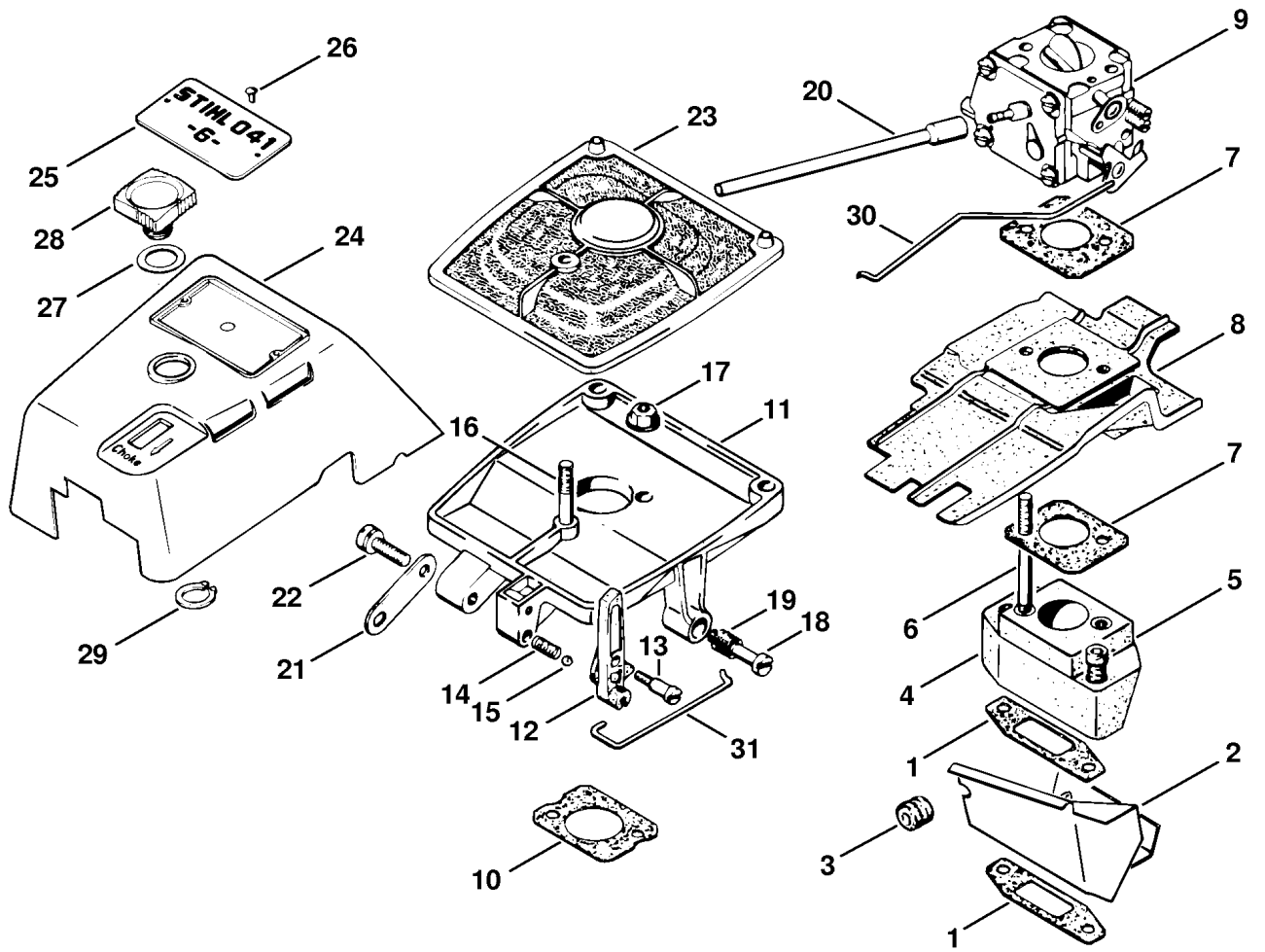

112ET006 LA

Reference	Item number	Qty	Description
1	1110 129 1401	2	Gasket
2	1110 146 7401	1	Deflecting plate
3	0000 989 0802	1	Grommet
4	1110 120 2201	1	Flange
5	9036 341 1070	2	Socket head screw M5x30
6	9123 319 0890	2	Stud M5x58
7	1111 129 1100	2	Gasket
8	1110 141 3000	1	Insulating plate
9	1110 120 0610	1	Carburetor HS-181C
10	1110 149 1200	1	Gasket
11	1110 140 2815	1	Filter housing □ 12 - 15
12	1111 185 2000	1	Choke lever
13	0000 951 2600	1	Oval head screw M4x10
14	0000 997 0326	1	Compression spring
15	9516 003 1720	1	Ball Ø 4 mm
16	9121 319 1030	1	Stud M5x22
17	9216 261 0700	2	Hexagon nut M5
18	1110 122 6201	1	Idle speed adjustment screw
19	0000 997 0626	1	Helical spring
20		1	Hose 3.1x5.7x120 mm (D)
	0000 930 2803	1	Hose 3.1x5.7 mm x 1 m (A,B)
21	1110 148 4000	1	Strap
22	9048 216 1010	1	Pan head screw M5x18
23	1110 120 1601	1	Air filter, flocked
24	1110 084 0604	1	Cover
25	0000 967 1569	1	Model plate 041 G
26	9441 065 1270	1	Round head rivet 2.6x6
27	0000 958 1705	1	Washer
28	1110 140 9500	1	Slotted nut
29	9455 621 1670	1	Circlip 16x1
30	1110 182 1505	1	Throttle rod
31	1110 185 1904	1	Choke rod

Reference	Item number	Qty	Description
	1110 120 0610	1	Carburetor HS-181C □ 1 - 30
1	1110 122 9410	1	Plug
2	1110 122 4200	1	Ball
3	1110 122 3000	1	Spring
4	1111 120 7200	1	Choke shaft with lever
5	1115 121 2900	1	Choke shutter
6	1110 129 0900	1	Gasket
7	1110 121 4700	1	Metering diaphragm
8	1110 121 0811	1	End cover
9	1106 122 7400	4	Round head screw
10	1110 121 4801	1	Fuel pump diaphragm
11	1110 129 1110	1	Gasket
12	1110 121 0815	1	End cover
13	1110 122 7700	4	Oval head screw
14	1110 122 6800	1	Low speed adjustment screw
15	1110 122 3030	1	Spring
16	1124 121 5000	1	Inlet control lever
17	1110 121 9200	1	Spindle
18	1110 122 7800	1	Oval head screw
19	1110 121 5100	1	Inlet needle
20	4221 121 7800	1	Strainer
21	1110 122 3020	1	Spring
22	1110 122 6700	1	High speed adjustment screw
23	1106 122 3000	1	Spring
24	1110 121 5400	1	Valve jet
25	1110 120 7100	1	Throttle shaft with lever
26	1110 122 9300	1	Clip
27	1110 122 7400	3	Round head screw
28	1110 122 3200	1	Torsion spring
29	1110 121 3300	1	Throttle shutter
30	1110 122 3900	1	Elbow connector

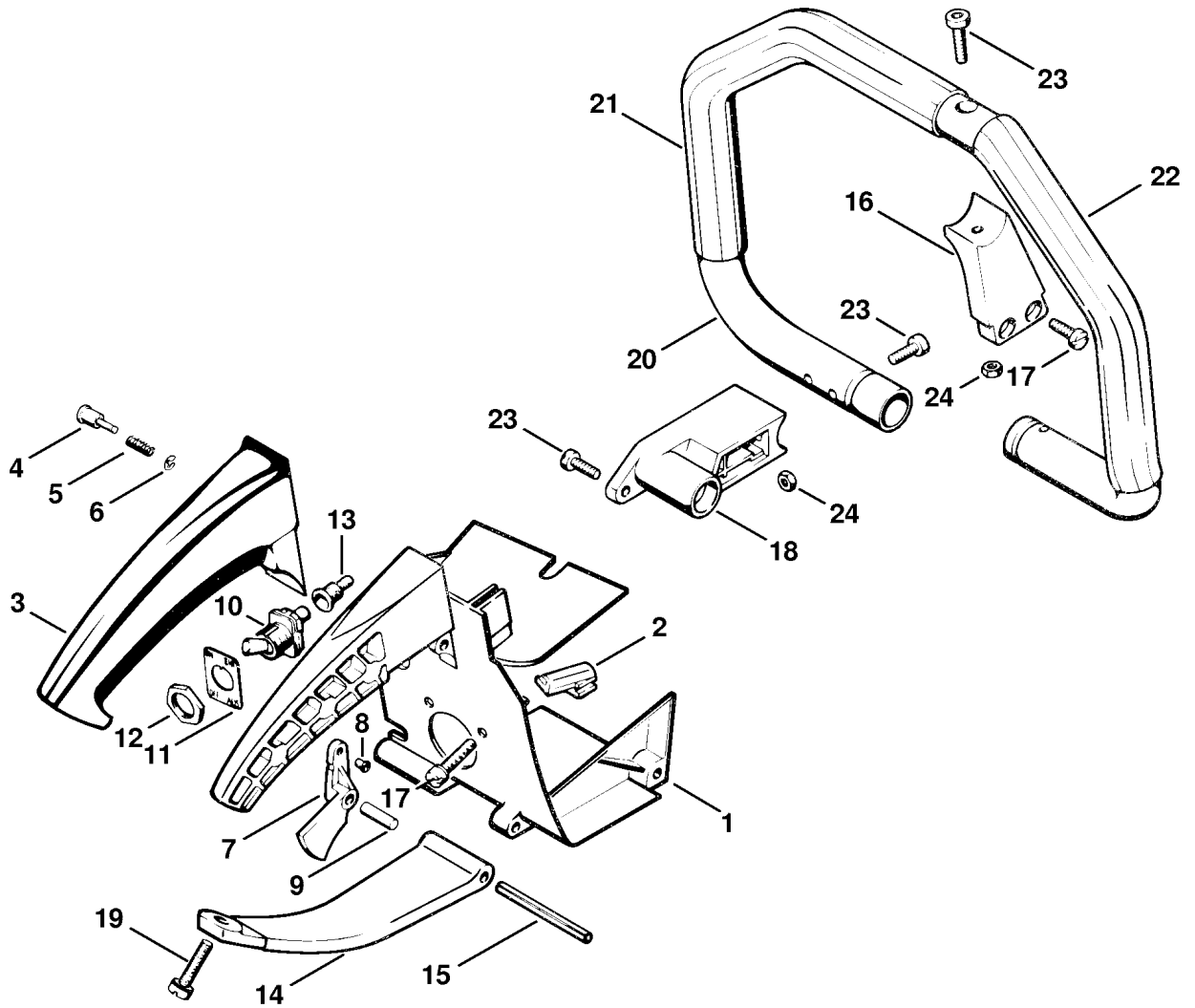

112ET008.LA

Reference	Item number	Qty	Description
1	1110 080 1601	1	Shroud
2	0000 989 0502	1	Clamp
3	1110 791 2200	1	Rubber grip
4	1108 180 1600	1	Starting throttle lock
5	0000 997 0603	1	Compression spring
6	9460 624 0320	1	E-clip 3.2
7	1110 180 1500	1	Throttle trigger □ 8
8	9415 415 2240	1	Hollow rivet 3x0.3x5
9	9373 542 2610	1	Cylindrical pin 5x18
10	1110 430 0202	1	Stop switch
11	0000 967 3506	1	Label
12	9211 260 1430	1	Hexagon nut M12x0.75
13	1110 432 9200	1	Grommet
14	1110 791 7600	1	Support
15	9380 620 2800	1	Roll pin 5x55
16	1110 791 1910	1	Handlebar holder
17	9048 216 1010	4	Pan head screw M5x18
18	1112 791 1900	1	Handlebar holder
19	9048 216 1050	1	Pan head screw M5x25
20	1112 790 3700	1	Wrap around handlebar with hose □ 21, 22
21	1110 791 2000	1	Handle hose
22	1110 791 2010	1	Handle hose
23	9036 341 0980	4	Socket head screw M5x16
24	9214 320 0700	5	Lock nut M5

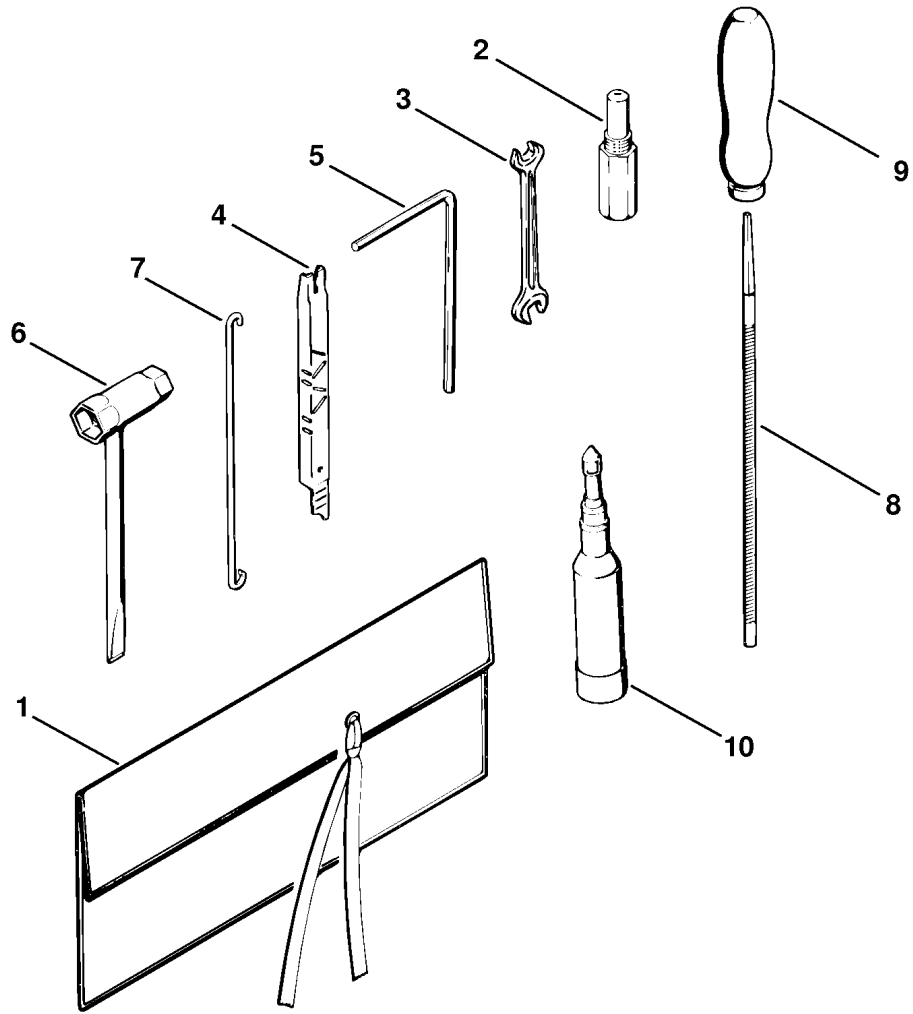

112ET009 LA

Reference	Item number	Qty	Description
	1110 890 1410	1	Tool kit □ 1 - 7
1	0000 891 0800	1	Tool roll
2	1107 191 1201	1	Locking screw
3	0811 012 1152	1	Wrench 8x10
4	1110 893 4000	1	Filing gauge
5	0811 270 1080	1	Allen key 4x70x130
6	1110 890 3401	1	Combination wrench
7	1110 893 8800	1	Hook Extras
8	0811 411 8108	1	Round file Ø 5.5x200 mm
9	0811 490 7860	1	File handle A100
10	1108 890 2500	1	Grease gun
	1110 007 1050	1	Set of gaskets (A)
	0000 792 9106	1	Chain scabbard (A)
	1110 007 1060	1	Set of carburetor parts (A)